

FLEXIBLE COUPLINGS N-BIPEX SERIES



General	9/3
Benefits	9/3
Application	9/4
Function	9/4
Design and configurations	9/5
Technical specifications	9/7
Assignment of N-BIPEX sizes to output PM of IEC standard motors	9/9
Type BWN	9/10
Type BWT – Variant A	9/11
Type BWT – Variant B	9/12
Type BWT – Variant AB	9/13
Type BNT	9/14
Spare and wear parts	9/15



GENERAL

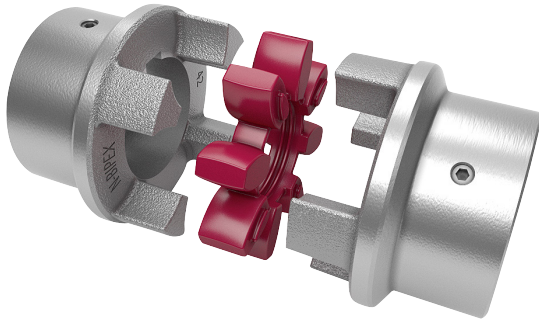

Coupling suitable for use in potentially explosive atmospheres.

Complies with the current ATEX Directive for:

CE  II 2G Ex h IIB T6 ... T4 Gb X

 II 2D Ex h IIIC T85 °C ... 120 °C Db X

 I M2 Ex h Mb X

N-BIPEX couplings are torsionally flexible and are outstanding for their particularly compact design and low weight.

N-BIPEX couplings are used in many areas of mechanical engineering.

Their main area of use is in electric motor drives which are well aligned and have uniform torque loads, such as in hydraulic applications and in combinations with geared motors.

Benefits

N-BIPEX couplings are suitable for horizontal, vertical and freely selectable mounting positions. They are able to absorb axial, radial and angular misalignment.

N-BIPEX couplings consist of two identical hub parts which can be arranged as required on the shaft extensions to be connected. N-BIPEX couplings transmit the torque positively and are thus fail-safe. The curved design of the cast cams ensures that the N-BIPEX couplings have a perfect pressure distribution and this increases the elastomer lifetime.

The flexible cam rings responsible for torque transmission and misalignment compensation are available in different Shore hardnesses. As a result of the good damping capability and by selecting the suitable stiffness, torque shock loads can thus be absorbed and the torsional vibration behavior of the drive can be positively influenced.

Different cam ring versions and ready-to-install hub parts are available from stock.

GENERAL

Application

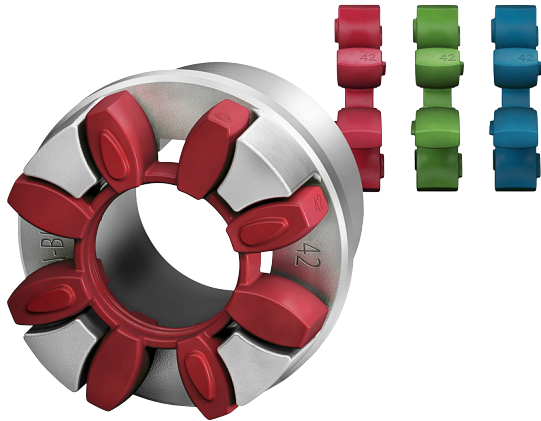

9

The N-BIPEX coupling is available as a catalog standard in 10 sizes with rated torques of between 12 Nm and 4650 Nm and is made of high-grade spheroidal graphite cast iron.

The extremely high-performance cam ring materials are available from stock in three different Shore hardnesses with the following colors:

- 92 ShoreA – red
- 95 ShoreA – green
- 64 ShoreD – blue

An additional size marking has been provided on the outer surface of the cam ring to be able to determine the size of the N-BIPEX even when it is in the assembled state without having to use any additional aids.

The coupling is suitable for use at ambient temperatures between -50 °C and $+100\text{ °C}$ without any restrictions on the rated torque as a result of temperature factors.

Function

The torque is transmitted to the hub at the drive end via the shaft-hub connection, which is mostly designed as a keyway connection, and is transmitted to the hub on the output side via the cam ring. This hub then further transmits the torque to the driven machine or a gear unit placed in between.

The special cam ring design helps to keep the compression-loaded cam ring elements in their defined position under all operating conditions and to keep them evenly loaded. This results in a long lifetime of the flexible elements.

A long lifetime is also guaranteed by the hub parts which ensure maximum operational reliability even under harsh operating conditions.

Design and configurations

The N-BIPEX coupling of type BWN comprises two identical hub parts connected by a cam ring of elastomer material.

The hubs are connected to the respective shafts via finished bores with parallel keyway connection or Taper clamping bushes. N-BIPEX couplings are positive-locking and torsionally flexible thanks to the thermoplastic polyurethane cam ring.

Coupling materials

Hubs:

- EN-GJS-400-15

Cam ring:

- TPU 92 ShoreA
-50 °C to +100 °C without any restrictions
- TPU 95 ShoreA
-50 °C to +100 °C without any restrictions
- TPU 64 ShoreD
-50 °C to +100 °C without any restrictions.

The coupling comprises the following:

- Cam ring
- 2 hub parts with identical cams.

The hub parts are designed with a bore and keyway to DIN 6885-1 or with a taper bore for mounting a Taper clamping bush.

Fitting the clamping bush connects the hub firmly to the machine shaft.

In the case of part 4 the Taper clamping bush is inserted from the machine housing side. If there is insufficient space, the Taper clamping bush cannot be fitted from this side. Besides space for fitting the Taper clamping bush, space for the fitting tool (offset screwdriver) must be taken into consideration. In the case of part 3, the Taper clamping bush is screwed in from the shaft end face side. The hub must be fitted before the machines to be connected are pushed together.

N-BIPEX coupling types

Type	Description
BWN	Coupling as a shaft-shaft connection with drilled and grooved hubs
BWT	Coupling as a shaft-shaft connection with Taper clamping bushes
BNT	Coupling as a shaft-shaft connection with drilled and grooved hubs and a Taper clamping bush

Technical specifications

Cam rings									
Size	Rated torque	Maximum torque	Fatigue torque	Maximum speed	Damping coefficient ψ	Torsional stiffness at 50 % capacity utilization	Permitted shaft misalignment at ¹⁾		
	T_{KN} Nm	T_{Kmax} Nm	T_{KW} Nm	$V \leq 45$ m/s n_{max} rpm		$C_{Tdyn 50\%}$ Nm/rad	< 10 Hz ΔK_a mm	n = 1500 rpm ΔK_r mm	ΔK_w degree
Cam rings of polyurethane 92 ShoreA (standard)									
19	12	36	2	19500	1.4	530	0.3	0.17	0.5
24	45	135	7	14500	1.4	1790	0.4	0.23	0.5
28	95	285	14	12500	1.4	3060	0.5	0.25	0.5
38	190	570	29	10000	1.4	6500	0.6	0.29	0.5
42	265	795	40	8500	1.4	8200	0.7	0.34	0.5
48	330	990	50	7500	1.4	10000	0.8	0.38	0.5
55	460	1380	70	6500	1.4	14500	0.9	0.4	0.5
65	670	2010	100	6000	1.4	25600	1	0.45	0.5
75	1400	4200	210	5000	1.4	37400	1.2	0.52	0.5
90	2500	7500	375	4000	1.4	62700	1.4	0.6	0.5
Cam rings of polyurethane 95 ShoreA (ordering option -Z and order code K01)									
19	18	54	3	19500	1.4	1130	0.27	0.15	0.4
24	65	195	10	14500	1.4	4240	0.36	0.21	0.4
28	160	480	25	12500	1.4	8050	0.45	0.23	0.4
38	325	975	50	10000	1.4	14100	0.54	0.26	0.4
42	450	1350	70	8500	1.4	16200	0.63	0.31	0.4
48	550	1650	85	7500	1.4	23300	0.72	0.34	0.4
55	700	2100	105	6500	1.4	28500	0.81	0.36	0.4
65	1000	3000	150	6000	1.4	35000	0.9	0.41	0.4
75	2000	6000	300	5000	1.4	66300	1.08	0.47	0.4
90	3700	11100	555	4000	1.4	105000	1.26	0.54	0.4
Cam rings of polyurethane 64 ShoreD (ordering option -Z and order code K04)									
19	25	75	5	19500	1.4	2010	0.24	0.14	0.3
24	90	270	15	14500	1.4	7680	0.32	0.18	0.3
28	200	600	30	12500	1.4	12200	0.4	0.2	0.3
38	405	1215	60	10000	1.4	25100	0.48	0.23	0.3
42	560	1680	84	8500	1.4	32000	0.56	0.27	0.3
48	700	2100	105	7500	1.4	41200	0.64	0.3	0.3
55	925	2775	140	6500	1.4	52600	0.72	0.32	0.3
65	1200	3600	180	6000	1.4	86700	0.8	0.36	0.3
75	2600	7800	390	5000	1.4	143000	0.96	0.42	0.3
90	4650	13950	700	4000	1.4	234000	1.12	0.48	0.3

¹⁾ The maximum speed must be observed. For further information on the allowable shaft misalignment, please refer to the operating instructions.

GENERAL

Torsional stiffness and damping

The values stated in the above table apply to a capacity utilization of 50 %, an excitation amplitude of 10 % T_{KN} with frequency 10 Hz and an ambient temperature of 20 °C. The dynamic torsional stiffness (C_{Tdyn}) is load-dependent and increases in proportion to capacity utilization. The following table shows the correction factors for different nominal load.

$$C_{Tdyn} = C_{Tdyn} 50 \% \cdot FKC$$

	Load T_N / T_{KN}						
	20%	40%	50%	60%	70%	80%	100%
Correction factor FKC							
92/95 ShoreA and	0.56	0.85	1	1.17	1.35	1.53	1.92
64 ShoreD							

Furthermore, torsional stiffness and damping depend on the ambient temperature, the frequency and the amplitude of the torsional vibration excitation. More precise torsional stiffness and damping parameters on request.

With flexible couplings the manufacturing process of the rubber elements and their aging primarily influence the stiffness value C_{Tdyn} . For this reason calculation must be made with a tolerance for the dynamic stiffness of $\pm 20\%$. The specified damping coefficient Ψ is a minimum value with the result that the damping performance of the coupling corresponds at least to the specified value.

Permitted shaft misalignment

The permitted shaft misalignment depends on the operating speed. As the speed increases, lower shaft misalignment values are permitted. The correction factors for different speeds are specified in the following table. The maximum speed depending on the respective coupling size and type must be observed!

$$\Delta K_{perm} = \Delta K_{1500} \cdot FKV$$

	Speed in rpm			
	500	1000	1500	3000
Correction factor FKV	1.20	1.10	1.00	0.70

The axial misalignment may occur dynamically at frequencies up to 10 Hz.

For fitting, the maximum gap dimension of $S2_{max.} = S2 + \Delta S2$ and the minimum gap dimension of $S2_{min.} = S2 - \Delta S2$ are permitted.

The shaft misalignments ΔK_a , ΔK_r and ΔK_w may occur simultaneously (see Page E/8).

Assignment of N-BIPEX sizes to output PM of IEC standard motors ¹⁾

Three-phase motor Size	Motor output at ≈ 3000 min ⁻¹		N-BIPEX coupling Size	Motor output at ≈ 1500 min ⁻¹		N-BIPEX coupling Size	Motor output at ≈ 1000 min ⁻¹		N-BIPEX coupling Size	Motor output at ≈ 750 min ⁻¹		N-BIPEX coupling Size	DE shaft end D x E acc. to IEC	
	P _M kW	T Nm		P _M kW	T Nm		P _M kW	T Nm		P _M kW	T Nm		D mm	E mm
80	0.75	2.5	19	0.55	3.7	19	0.37	3.9	19	0.18	2.5	19	19	40
	1.1	3.7	19	0.75	5.1	19	0.55	5.8	19	0.25	3.5	19		
90S	1.5	5	19	1.1	7.5	19	0.75	8	19	0.37	5.3	19	19	40
90L	2.2	7.4	19	1.5	10	24	1.1	12	24	0.55	7.9	24	19	40
													24	50
100L	3	9.8	24	2.2	15	24	1.5	15	24	0.75	11	24	28	60
				3	20	24				1.1	16	24		
112M	4	13	24	4	27	24	2.2	22	24	1.5	21	24	28	60
132S	5.5	18	28	5.5	36	28	3	30	28	2.2	30	28	38	80
	7.5	25	28											
132M				7.5	49	28	4	40	28	3	40	28	38	80
							5.5	55	28					
160M	11	36	38	11	72	38	7.5	75	38	4	54	38	42	110
	15	49	38							5.5	74	38		
160L	18.5	60	38	15	98	38	11	109	38	7.5	100	38	42	110
180M	22	71	38	18.5	121	38							48	110
180L				22	144	38	15	148	42	11	145	42	48	110
200L	30	97	42	30	196	42	18.5	181	42	15	198	42	55	110
	37	120	42				22	215	42					
225S				37	240	48				18.5	244	48	60	140
225M	45	145	42										55	110
				45	292	55	30	293	55	22	290	55	60	140
250M	55	177	48										60	140
				55	356	55	37	361	55	30	392	65	65	140
280S	75	241	55										65	140
				75	484	65	45	438	65	37	483	65	75	140
280M	90	289	55										65	140
				90	581	75	55	535	75	45	587	75	75	140
315S	110	353	55										65	140
				110	707	75	75	727	75	55	712	75	80	170
315M	132	423	65										65	140
				132	849	75	90	873	75	75	971	75	80	170
315L	160	513	65										65	140
	200	641	75											
				160	1030	75	110	1070	75	90	1170	90	80	170
				200	1290	90	132	1280	90	110	1420	90		
315	250	802	75										65	140
	315	1010	90											
355				250	1600	90	200	1930	90				85	170
	355	1140	90										75	140
	400	1280	90										75	140
	500	1600	90										75	140
400	560	1790	90									80	170	

¹⁾ The assignment applies for an service factor of 1.25 and the use of a standard cam ring (92 ShoreA).

TYPE BWN

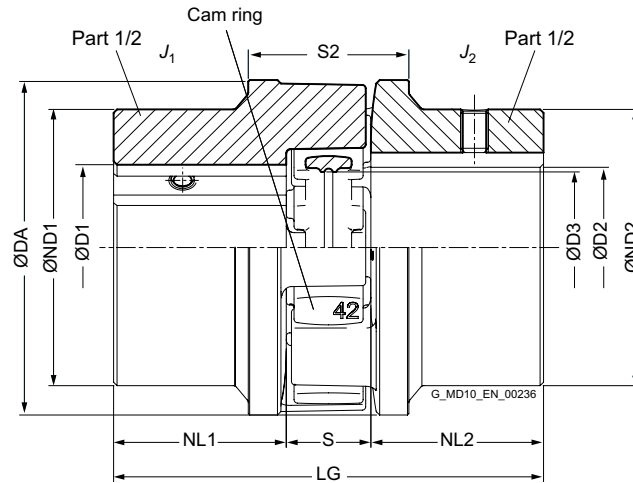

9

Size	Rated torque			Speed n_{Kmax} rpm	Dimensions in mm										Mass moment of inertia J_1/J_2 kgm ²	Article no. ¹⁾	Weight m kg
	T_{KN}		64ShoreD Nm		D1/D2 Keyway DIN 6885 min.	DA	ND1/ ND2	NL1/ NL2	D3	S	S2	$\Delta S2$	LG				
	92 ShoreA Nm	95 ShoreA Nm												max.			
19	12	18	25	19500	0	25	42	38	25	17	16	31	1	66	0.000045	2LC0160-0AA	0.3
24	45	65	90	14500	0	35	57	50	30	25	18	37	1.5	78	0.00015	2LC0160-1AA	0.6
28	95	160	200	12500	0	40	67	58	35	28	20	41	1	90	0.00033	2LC0160-2AA	1
38	190	325	405	10000	0	48	82	68	45	36	24	45	1.5	114	0.0009	2LC0160-3AA	1.7
42	265	450	560	8500	0	55	97	80	50	43	26	48	1.5	126	0.0019	2LC0160-4AA	2.6
48	330	550	700	7500	0	62	107	90	56	48	28	50	2	140	0.0031	2LC0160-5AA	3.6
55	460	700	925	6500	0	75	123	105	65	57	30	60	2	160	0.006	2LC0160-6AA	5.2
65	670	1000	1200	6000	0	82	138	115	75	64	35	65	2.5	185	0.011	2LC0160-7AA	7.5
75	1400	2000	2600	5000	0	96	163	135	85	76	40	75	2.5	210	0.023	2LC0160-8AA	11.5
90	2500	3700	4650	4000	0	120	203	170	100	95	45	85	3	245	0.065	2LC0161-0AA	21.4

Configurable variants ¹⁾

- ØD1 Without finished bore
With finished bore
- ØD2 Without finished bore
With finished bore
- Cam ring hardness **92 ShoreA**
95 ShoreA
64 ShoreD

Notes

- Mass moments of inertia apply to a coupling half with maximum bore diameter.
- Weights apply to a whole coupling in the version with maximum bore.

Ordering example

- N-BIPEX coupling BWN, size 42
- Part 1/2: Bore D1 42 H7 mm, with keyway to DIN 6885-1 and set screw
- Part 1/2: Bore D2 32 H7 mm, with keyway to DIN 6885-1 and set screw
- Cam ring hardness 92 ShoreA

Article no.: 2LC0160-4AA99-0AA0-Z L0X+M0T

¹⁾ To identify complete item numbers specifying the available finish boring options and – if necessary – further order options, please use our configurators on flender.com.

➤ For online configuration on flender.com, click on the item no.

TYPE BWT

Variant A

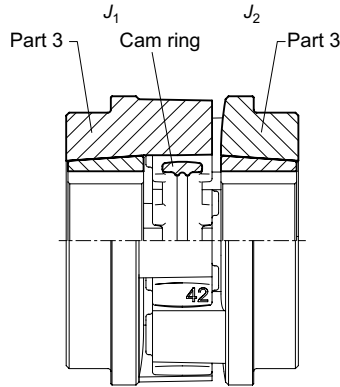

Variant A

Size	Taper Clamping Bush Size	Rated torque		Speed	Dimensions in mm										Mass moment of inertia J_1/J_2	Article no. ¹⁾	Weight		
		T_{KN}			n_{Kmax}	D1/D2 Keyway DIN 6885	DA	ND1/ND2	NL1/NL2	D3	S	S2	ΔS2	LG				Type	m
		92 ShoreA	95 ShoreA																
24	1008	45	65	14500	10	25	57	54	23	25	18	37	1.5	64	0.00015	2LC0160-1AB	0.6		
28	1108	95	160	12500	10	28	67	58	23	28	20	41	1	66	0.00025	2LC0160-2AB	0.8		
38	1108	190	325	10000	10	28	82	58	23	36	24	45	1.5	70	0.0005	2LC0160-3AB	1.2		
42	1610	265	450	8500	14	42	97	86	26	43	26	48	1.5	78	0.0013	2LC0160-4AB	1.8		
48	1615	330	550	7500	14	42	107	80	39	48	28	50	2	106	0.002	2LC0160-5AB	2.6		
55	2012	460	700	6500	14	50	123	100	33	57	30	60	2	96	0.004	2LC0160-6AB	3.5		
65	2012	670	1000	6000	14	50	138	100	33	64	35	65	2.5	101	0.006	2LC0160-7AB	4.5		
	2517 ²⁾				55	60								118			46	127	0.008
75	2517	1400	2000	5000	16	60	163	118	46	76	40	75	2.5	132	0.015	2LC0160-8AB	7.7		
	3020 ²⁾				65	75								142			52	144	0.017
90	3020	2500	3700	4000	25	75	205	142	52	95	45	85	3	149	0.037	2LC0161-0AB	12.9		
	3535 ²⁾				80	90								170			90	225	0.06

Configurable variants ¹⁾

- ØD1 Without Taper clamping bush
With Taper clamping bush
- ØD2 Without Taper clamping bush
With Taper clamping bush
- Cam ring hardness **92 ShoreA**
95 ShoreA

Notes

- Mass moments of inertia apply to a coupling half without Taper clamping bush.
- Weights apply to a whole coupling in the version without Taper clamping bush.
- T_{Kmax} for the 95 ShoreA cam ring is limited to $2 \times T_{KN}$ for types BWT and BNT contrary to the table on Page 9/7. When using the 64 ShoreD cam ring, the same torque values apply as for the 95 ShoreA cam ring.

Ordering example

- N-BIPEX BWT coupling, size 42, variant A
- Part 3: With Taper clamping bushes, size 1610, bore D1 38 H7 mm, with keyway to DIN 6885-1
- Part 4: With Taper clamping bushes, size 1610, bore D2 32 H7 mm, with keyway to DIN 6885-1
- Cam ring hardness 92 ShoreA

Article no.: 2LC0160-4AB99-0AA0-Z L0V+M0T

¹⁾ To identify complete item numbers specifying the available finish boring options and – if necessary – further order options, please use our configurators on flender.com.

²⁾ Taper clamping bush version only possible in part 4.

➤ For online configuration on flender.com, click on the item no.

TYPE BWT

Variant B

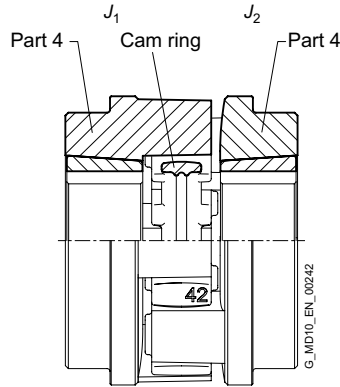

Variant B

Size	Taper Clamping Bush Size	Rated torque		Speed n_{Kmax} rpm	Dimensions in mm										Mass moment of inertia J_1/J_2 kgm ²	Article no. ¹⁾ Type B	Weight m kg
		T_{KN}			D1/D2 Keyway DIN 6885	DA	ND1/ ND2	NL1/ NL2	D3	S	S2	$\Delta S2$	LG				
		92 ShoreA Nm	95 ShoreA Nm											min.			
24	1008	45	65	14500	10	25	57	54	23	25	18	37	1.5	64	0.00015	2LC0160-1AC	0.6
28	1108	95	160	12500	10	28	67	58	23	28	20	41	1	66	0.00025	2LC0160-2AC	0.8
38	1108	190	325	10000	10	28	82	58	23	36	24	45	1.5	70	0.0005	2LC0160-3AC	1.2
42	1610	265	450	8500	14	42	97	86	26	43	26	48	1.5	78	0.0013	2LC0160-4AC	1.8
48	1615	330	550	7500	14	42	107	80	39	48	28	50	2	106	0.002	2LC0160-5AC	2.6
55	2012	460	700	6500	14	50	123	100	33	57	30	60	2	96	0.004	2LC0160-6AC	3.5
65	2012	670	1000	6000	14	50	138	100	33	64	35	65	2.5	101	0.006	2LC0160-7AC	4.5
	2517 ²⁾				55	60								118	46		127
75	2517	1400	2000	5000	16	60	163	118	46	76	40	75	2.5	132	0.015	2LC0160-8AC	7.7
	3020 ²⁾				65	75								142	52		144
90	3020	2500	3700	4000	25	75	205	142	52	95	45	85	3	149	0.037	2LC0161-0AC	12.9
	3535 ²⁾				80	90								170	90		225

Configurable variants ¹⁾

- ØD1 Without Taper clamping bush
With Taper clamping bush
- ØD2 Without Taper clamping bush
With Taper clamping bush
- Cam ring hardness **92 ShoreA**
95 ShoreA

Notes

- Mass moments of inertia apply to a coupling half without Taper clamping bush.
- Weights apply to a whole coupling in the version without taper clamping bush.
- T_{Kmax} for the 95 ShoreA cam ring is limited to $2 \times T_{KN}$ for types BWT and BNT contrary to the table on Page 9/7. When using the 64 ShoreD cam ring, the same torque values apply as for the 95 ShoreA cam ring.

Ordering example

- N-BIPEX BWT coupling, size 42, variant B
- Part 3: With Taper clamping bushes, size 1610, bore D1 38 H7 mm, with keyway to DIN 6885-1
- Part 4: With Taper clamping bushes, size 1610, bore D2 32 H7 mm, with keyway to DIN 6885-1
- Cam ring hardness 92 ShoreA

Article no.: 2LC0160-4AC99-0AA0-Z L0V+M0T

¹⁾ To identify complete item numbers specifying the available finish boring options and – if necessary – further order options, please use our configurators on flender.com.

²⁾ Taper clamping bush version only possible in part 4.

➤ For online configuration on flender.com, click on the item no.

TYPE BWT

Variant AB

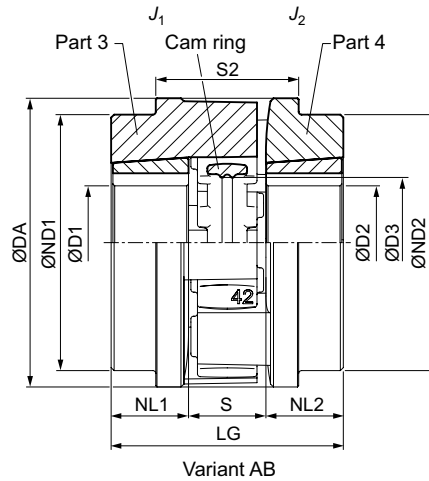

Size	Taper Clamping Bush Size	Rated torque		Speed n_{Kmax} rpm	Dimensions in mm										Mass moment of inertia J_1/J_2 kgm ²	Article no. ¹⁾	Weight m kg
		T_{KN}			D1/D2 Keyway DIN 6885	DA	ND1/ ND2	NL1/ NL2	D3	S	S2	ΔS2	LG				
		92 ShoreA Nm	95 ShoreA Nm											min.			
24	1008	45	65	14500	10	25	57	54	23	25	18	37	1.5	64	0.00015	2LC0160-1AD	0.6
28	1108	95	160	12500	10	28	67	58	23	28	20	41	1	66	0.00025	2LC0160-2AD	0.8
38	1108	190	325	10000	10	28	82	58	23	36	24	45	1.5	70	0.0005	2LC0160-3AD	1.2
42	1610	265	450	8500	14	42	97	86	26	43	26	48	1.5	78	0.0013	2LC0160-4AD	1.8
48	1615	330	550	7500	14	42	107	80	39	48	28	50	2	106	0.002	2LC0160-5AD	2.6
55	2012	460	700	6500	14	50	123	100	33	57	30	60	2	96	0.004	2LC0160-6AD	3.5
65	2012	670	1000	6000	14	50	138	100	33	64	35	65	2.5	101	0.006	2LC0160-7AD	4.5
	2517 ²⁾				55	60								118			46
75	2517	1400	2000	5000	16	60	163	118	46	76	40	75	2.5	132	0.015	2LC0160-8AD	7.7
	3020 ²⁾				65	75								142			52
90	3020	2500	3700	4000	25	75	205	142	52	95	45	85	3	149	0.037	2LC0161-0AD	12.9
	3535 ²⁾				80	90								170			90

Configurable variants ¹⁾

- ØD1 Without Taper clamping bush
With Taper clamping bush
- ØD2 Without Taper clamping bush
With Taper clamping bush
- Cam ring hardness **92 ShoreA**
95 ShoreA

Notes

- Mass moments of inertia apply to a coupling half without Taper clamping bush.
- Weights apply to a whole coupling in the version without taper clamping bush.
- T_{Kmax} for the 95 ShoreA cam ring is limited to $2 \times T_{KN}$ for types BWT and BNT contrary to the table on Page 9/7. When using the 64 ShoreD cam ring, the same torque values apply as for the 95 ShoreA cam ring.

Ordering example

- N-BIPEX BWT coupling, size 42, variant AB
- Part 3: With Taper clamping bushes, size 1610, bore D1 38 H7 mm, with keyway to DIN 6885-1
- Part 4: With Taper clamping bushes, size 1610, bore D2 32 H7 mm, with keyway to DIN 6885-1
- Cam ring hardness 92 ShoreA

Article no.: 2LC0160-4AD99-0AA0-Z L0V+M0T

¹⁾ To identify complete item numbers specifying the available finish boring options and – if necessary – further order options, please use our configurators on flender.com.

²⁾ Taper clamping bush version only possible in part 4.

➤ For online configuration on flender.com, click on the item no.

TYPE BNT

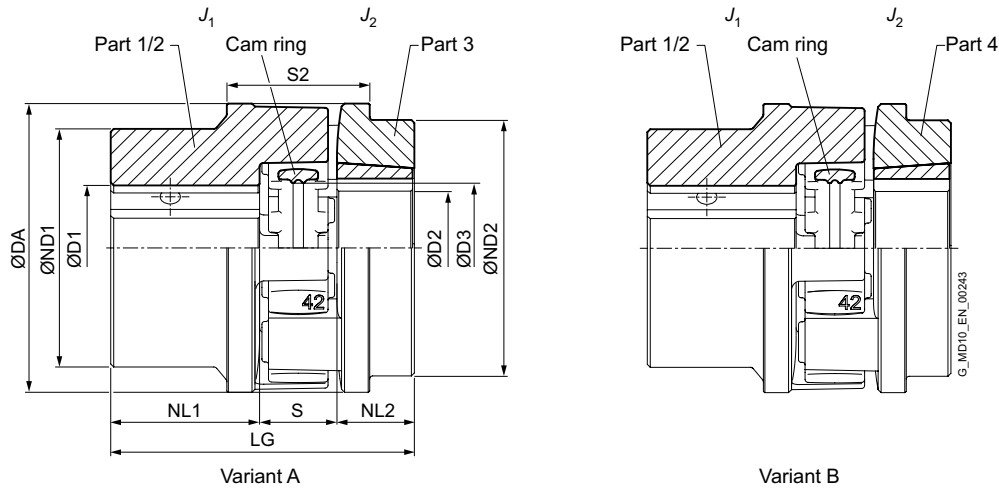

9

Size	Taper Clamping Bush Size	Rated torque		Speed n_{Kmax} rpm	Dimensions in mm															Mass moment of inertia		Article no. ¹⁾		Weight m kg
		T_{KN}	T_{KN}		D1 Keyway DIN 6885 min. max.	D2 Keyway DIN 6885 min. max.	DA	ND1	ND2	NL1	NL2	D3	S	S2	$\Delta S2$	LG	J_1 kgm ²	J_2 kgm ²	Type	Type				
		92 ShoreA Nm	95 ShoreA Nm																A	B				
24	1008	45	65	14500	0	35	10	25	57	50	54	30	23	25	18	37	1.5	71	0.00015	0.00015	2LC0160-1AE	2LC0160-1AF	0.6	
28	1108	95	160	12500	0	40	10	28	67	58	58	35	23	28	20	41	1	78	0.0003	0.0002	2LC0160-2AE	2LC0160-2AF	0.8	
38	1108	190	325	10000	0	48	10	28	82	68	58	45	23	36	24	45	1.5	92	0.0009	0.0005	2LC0160-3AE	2LC0160-3AF	1.4	
42	1610	265	450	8500	0	55	14	42	97	80	86	50	26	43	26	48	1.5	102	0.002	0.0013	2LC0160-4AE	2LC0160-4AF	2.3	
48	1615	330	550	7500	0	62	14	42	107	90	80	56	39	48	28	50	2	123	0.003	0.002	2LC0160-5AE	2LC0160-5AF	3.2	
55	2012	460	700	6500	0	75	14	50	123	105	100	65	33	57	30	60	2	128	0.006	0.004	2LC0160-6AE	2LC0160-6AF	4.4	
65	2012	670	1000	6000	0	82	14	50	138	115	100	75	33	64	35	65	2.5	143	0.011	0.006	2LC0160-7AE	2LC0160-7AF	6	
	6.5																							
75	2517 ²⁾	1400	2000	5000	0	96	160	60	163	135	118	85	46	76	40	75	2.5	171	0.023	0.014	2LC0160-8AE	2LC0160-8AF	9.4	
	9.6																							
90	3020 ²⁾	2500	3700	4000	0	120	25	75	205	170	142	100	52	95	45	85	3	197	0.065	0.036	2LC0161-0AE	2LC0161-0AF	17.2	
	20.7																							

Configurable variants ¹⁾

- Type: A, B
- ØD1: Without Taper clamping bush, With Taper clamping bush
- ØD2: Without Taper clamping bush, With Taper clamping bush
- Cam ring hardness: 92 ShoreA, 95 ShoreA

Ordering example

- N-BIPEX BNT coupling, size 42, variant B
 - Part 1/2: Bore D1 42 H7 mm, with keyway to DIN 6885-1 and set screw
 - Part 4: With Taper clamping bushes, size 1610, bore D2 32 H7 mm, with keyway to DIN 6885-1
 - Cam ring hardness 92 ShoreA
- Article no.: 2LC0160-4AF99-0AA0-Z LOX+M0T

Notes

- Mass moments of inertia apply to a coupling half with maximum bore diameter and without Taper clamping bush.
- Weights apply to a whole coupling in the version without taper clamping bush.
- T_{Kmax} for the 95 ShoreA cam ring is limited to $2 \times T_{KN}$ for types BWT and BNT contrary to the table on Page 9/7. When using the 64 ShoreD cam ring, the same torque values apply as for the 95 ShoreA cam ring.

¹⁾ To identify complete item numbers specifying the available finish boring options and – if necessary – further order options, please use our configurators on flender.com.
²⁾ Taper clamping bush version only possible in part 4.
[↗] For online configuration on flender.com, click on the item no.

SPARE AND WEAR PARTS

Cam rings of the N-BIPEX coupling

Size	Article no. N-BIPEX cam ring			Weight kg
	92 ShoreA	95 ShoreA	64 ShoreA	
19	2LC0160-0WA00-0AA0	2LC0160-0WA00-0AA0-Z K01	2LC0160-0WA00-0AA0-Z K04	0.006
24	2LC0160-1WA00-0AA0	2LC0160-1WA00-0AA0-Z K01	2LC0160-1WA00-0AA0-Z K04	0.02
28	2LC0160-2WA00-0AA0	2LC0160-2WA00-0AA0-Z K01	2LC0160-2WA00-0AA0-Z K04	0.03
38	2LC0160-3WA00-0AA0	2LC0160-3WA00-0AA0-Z K01	2LC0160-3WA00-0AA0-Z K04	0.04
42	2LC0160-4WA00-0AA0	2LC0160-4WA00-0AA0-Z K01	2LC0160-4WA00-0AA0-Z K04	0.07
48	2LC0160-5WA00-0AA0	2LC0160-5WA00-0AA0-Z K01	2LC0160-5WA00-0AA0-Z K04	0.09
55	2LC0160-6WA00-0AA0	2LC0160-6WA00-0AA0-Z K01	2LC0160-6WA00-0AA0-Z K04	0.1
65	2LC0160-7WA00-0AA0	2LC0160-7WA00-0AA0-Z K01	2LC0160-7WA00-0AA0-Z K04	0.2
75	2LC0160-8WA00-0AA0	2LC0160-8WA00-0AA0-Z K01	2LC0160-8WA00-0AA0-Z K04	0.4
90	2LC0161-0WA00-0AA0	2LC0161-0WA00-0AA0-Z K01	2LC0161-0WA00-0AA0-Z K04	0.6

Note

- The cam rings of the N-BIPEX coupling are wear parts. The service life depends on the operating conditions.

